

Maintenance and Commissioning Literature for **J48Z & P** *Zero & Proportionator* *$\frac{3}{4}$ " – 2" Sizes*

CONTENTS

General Arrangement <i>Units from October 1997</i>	<i>D4821D</i>
General Arrangement <i>Units up to September 1997</i>	<i>D4805C</i>
Maintenance Instructions <i>Units from October 1997</i>	<i>M4803E</i>
Maintenance Instructions <i>Units up to September 1997</i>	<i>M4806C</i>
Parts List <i>All Types and Sizes</i>	<i>PL4803L</i>
Commissioning Instructions <i>All Types and Sizes</i>	<i>C4815A</i>

For all 1¼" – 2" units, and ¾" – 1" units fitted with Compression Spring
(from October 1997)

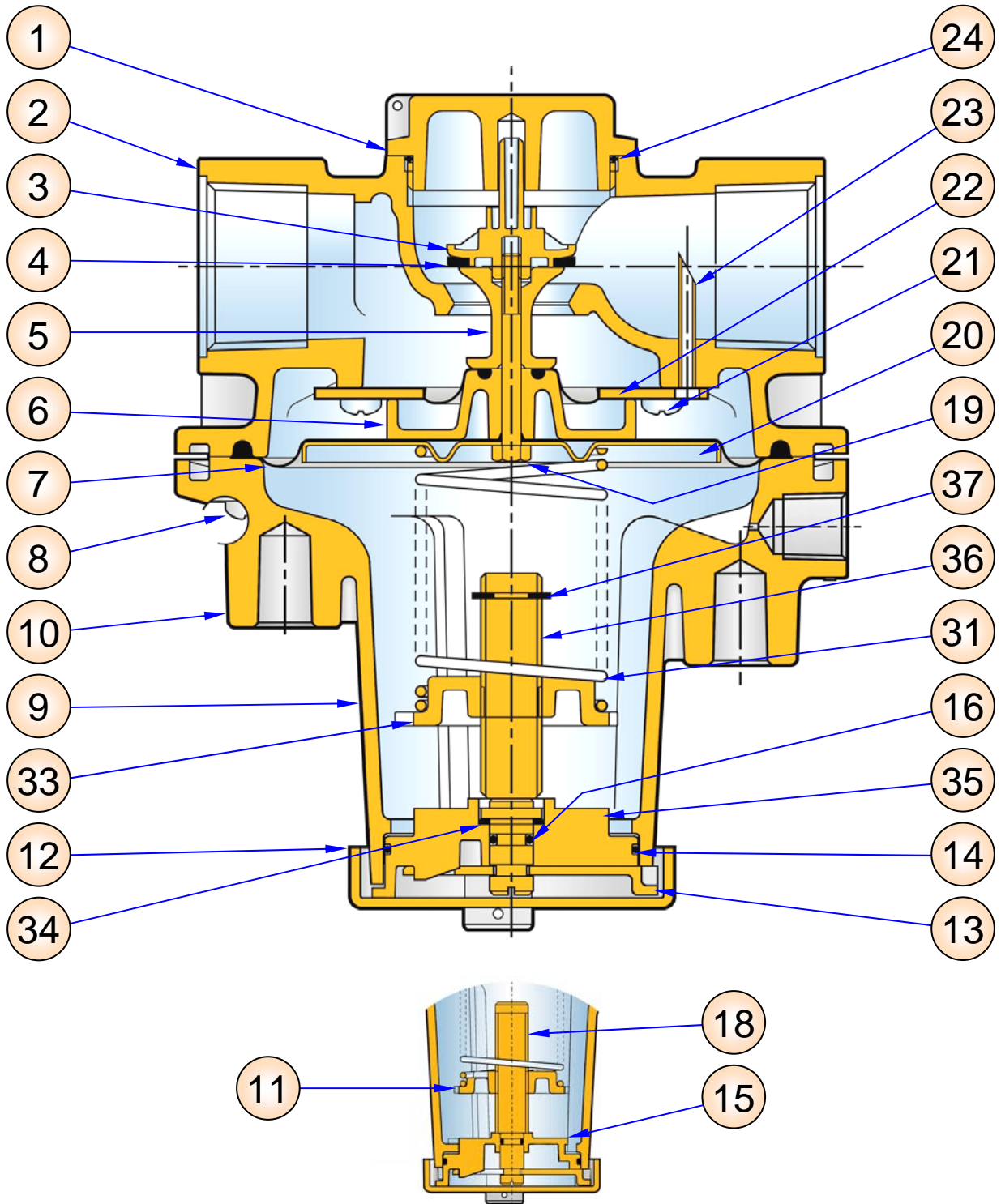

Spring Adjustment
Pre October 2000

For all ¾" & 1" units fitted with Tension Spring (up to September 1997)

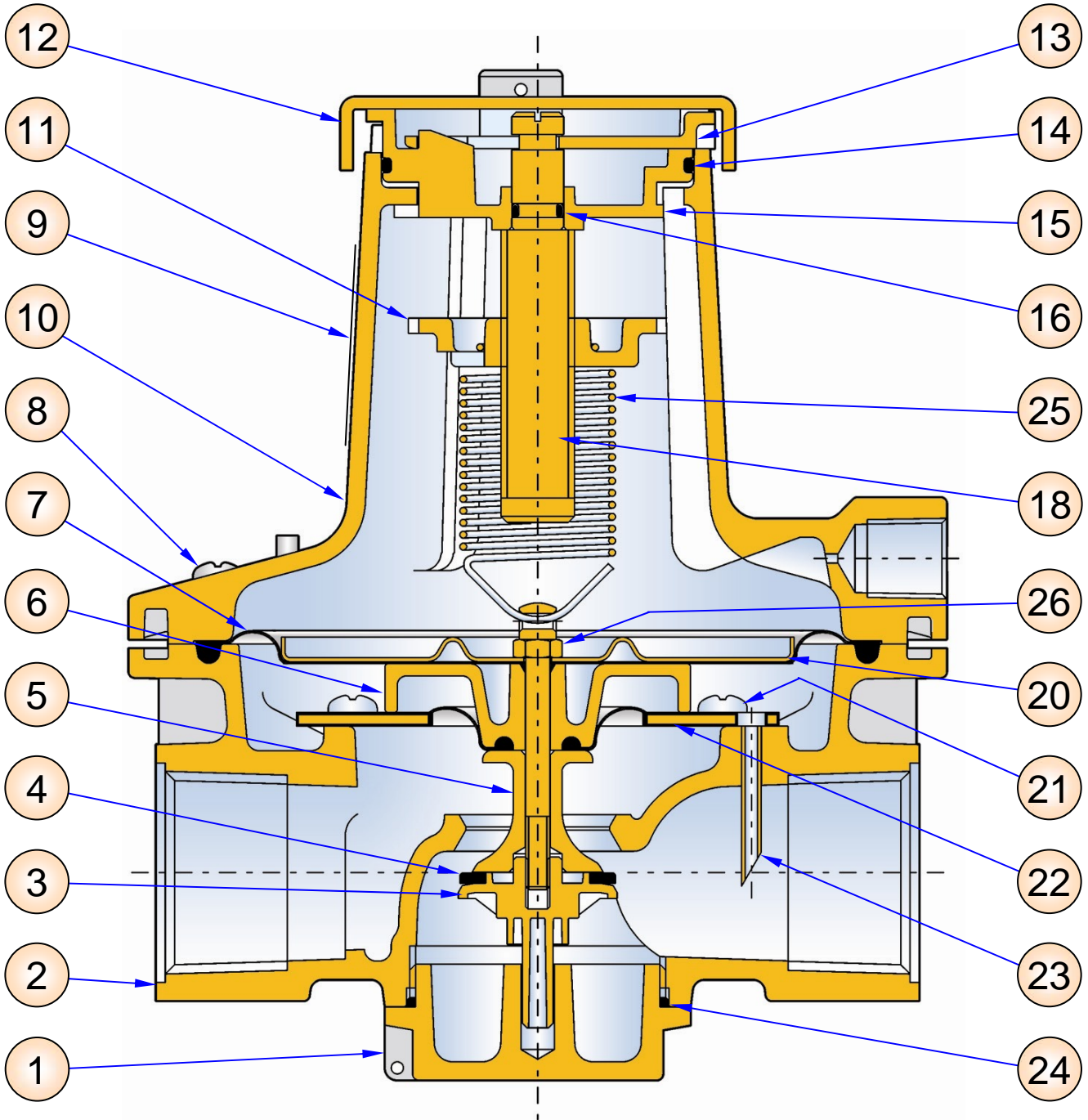

DATASHEET D4805 ISSUE C FEBRUARY 1998

MAINTENANCE

Maintenance Instructions for: J48 MKII Regulator 1/2" - 2",
J48 MKII Angled Regulator 1/2" - 2", J48 MKII Meter Union
Regulator 1/2" - 2" and J48 MKII Zero / Proportionator 1/2" - 2"

Diagram Reference Sheet No. D.48.04, D48.06, D.48.11 & D.48.21

Parts List Reference Sheet No. PL.48.03

Dismantling Procedure:

1. Pull off top cap (12).
2. Turn spring adjusting screw (36) anti-clockwise (to reduce loading on spring).
3. Carefully lift protruding end of locking lever (13) just above adjusting bush (35) whilst in this position turn (octagon shaped) adjusting bush (35) assembly anti-clockwise until disengaged. The adjusting bush (35) can then be removed from the top cover (10).
4. Remove the loading spring (17) from the top cover (10).

NOTE: If adjusting bush assembly is to be dismantled for "o" ring replacement, follow procedure. If to be left assembled proceed to instruction number 9.

5. Lift keyhole end of locking lever (13) over sloping peg in adjusting bush (35), and slide forward until, disengaged from spring adjusting screw (36) and remove.
6. Pull spring adjusting screw (36) from adjusting bush (35).
7. Remove "O" rings (16) & (14) from spring adjusting screw (36) and adjusting bush (35) respectively.
8. Lift washer (34) from spring adjusting screw (36) and remove.
9. Remove top cover screws (8) then carefully remove the top cover (10).
- 10.1 For J48 Regulator & J48 Zero / Proportionator: Unscrew bottom plug (1) and remove from body (2).
- 10.2 For J48 Angled Regulator: Unscrew outlet adaptor bush (28) and remove from body (2).
- 10.3 For J48 Meter Union Regulator: Unscrew meter union assembly (29) and remove from body (2).
11. Remove "O" ring (24) from (1), (28) or (29).
12. Restrain valve disc holder (3) with suitable box spanner and unscrew the valve spindle (19).
13. Withdraw the valve disc holder (3), valve disc (4) and valve spacer (5) through the bottom plug opening.
14. Remove the valve spindle (19).
15. Remove the top diaphragm plate (20).
16. Carefully remove main diaphragm (7).
17. Remove diaphragm spacer (6).
18. Remove secondary diaphragm screws (21).
19. Carefully remove the secondary diaphragm (22).
20. Check hole in impulse tube (23) is clear. DO NOT REMOVE FROM BODY.
21. Wipe valve seat and body clean of any dirt particles, taking care not to damage sealing surface in body.
22. Inspect all diaphragms and soft seals and replace where necessary (a spares kit is available for this purpose).
23. For J48 Angled Regulator and J48 Meter Union Regulator do not remove counter sunk plug (27) unless required.
24. For J48 Meter Union Regulator, Do not remove inlet adaptor bush (30), unless required. Note: in some instances an inlet filter may be incorporated into this bush. Remove filter and clean.

Rebuilding procedure:

1. Locate secondary diaphragm (22) with convolution uppermost on to the body (2). Ensure screw holes and impulse tube holes are aligned correctly.
2. Secure secondary diaphragm (22) in position using screws (21).
3. Place diaphragm spacer (6) on secondary diaphragm (22) ensuring diaphragm bead is located correctly in the groove.
4. Place main diaphragm (7) with convolution uppermost, ensuring that the bead is located in the groove in the body (2).
5. Locate the top diaphragm plate (20) ensuring raised edge is uppermost.
6. Insert the valve spindle (19) through the centre hole in top diaphragm plate (20), main diaphragm (7) and diaphragm spacer (6).
7. Locate valve spacer (5) on to valve spindle (19) through bottom plug opening.
8. Assemble valve disc (4) on to valve disc holder (3) with bead uppermost.
9. Screw valve disc holder (3) complete with valve disc (4) on to threaded end of valve spindle (19) through bottom plug opening. **DO NOT TIGHTEN.**
10. Restrain valve disc holder (3) with suitable box spanner and tighten valve spindle (19).
11. Place "O" ring seal (24) into "O" ring seal groove in bottom plug (1), outlet adaptor bush (28) or meter union assembly (29).
12. Replace the component (1), (28) or (29) complete with "O" ring over centre shaft of valve disc holder (3) into body (2) and screw tightly in position.
13. Carefully replace top cover (10) on to body (2) with vent facing the outlet and secure with top cover screws (8).
14. Insert loading spring (17) over spring location ridge in top diaphragm plate (20).

NOTE: If adjusting bush assembly (35) has been dismantled follow procedure, if it has been left assembled then proceed to instruction number 21.

15. Slide "O" ring seal (16) over slotted end of spring adjusting screw (36) into second groove. (i.e. groove nearest thread).
16. Replace washer (34) over slotted end of spring adjusting screw (36) and slide down until it sits on shoulder of adjusting screw.
17. Slide "O" ring seal (14) into "O" ring groove on adjusting bush (35).
18. Push spring adjusting screw (36) into hole in the bottom of the adjusting bush (35) until parts are firmly together.
19. Position key hole slot in locking lever (13) over slotted end of spring adjusting screw (35) and slide over slopping peg in adjusting bush (35) until firmly locked in position.
20. Screw top spring holder (33) anti-clockwise to within 10mm of underside of adjusting bush (35).
21. Position underside of top spring holder (33) on to loading spring (17).
22. Align slots in top spring holder (33) with splines in top cover (10) and push adjusting bush (35) assembly into top cover (10) as far as possible.
23. Turn adjusting bush assembly (35) clockwise until locking lever (13) snaps into any of the three locking castellations in top cover (10).
24. Set units to required pressure.
25. Replace top cap (12) by aligning slot in cap with sealing wire lug and push over until it clicks into position, and seal if necessary.

MAINTENANCE

Maintenance Instructions for J48 MKII Zero Regulator and Proportionator. For 3/4" and 1" Units Fitted with Tension Spring (up to September 1997)

For units built from October 1997 see maintenance data sheet for J48 regulator – M4803

Diagram Reference Sheet No. D.4805

Parts List Reference Sheet No. PL.4803

Dismantling Procedure:

1. Pull off top cap (12).
 2. Turn spring adjusting screw (18) clockwise (to reduce tension on spring).
 3. Remove top cover screws (8), tilt top cover (10) and unhook tension spring (25) from valve spindle (26).
 4. Carefully lift top cover (10) from body (2).
- NOTE: If adjusting bush assembly is to be dismantled for "O" ring replacement, follow procedure. if to be left assembled proceed to instruction number 11.
5. From the underside of the top cover (10) remove tension spring (25) by turning spring clockwise.
 6. Carefully lift protruding end of locking lever (13) just clear of adjusting bush (15), whilst in this position turn (octagon shaped) adjusting bush (15) assembly anti-clockwise until disengaged. Lift spring adjusting bush (15) assembly from top cover (10).
 7. Lift keyhole end of locking lever (13) over sloping peg in adjusting bush (15), and slide forward until disengaged from spring adjusting screw (18) and remove.
 8. Pull spring adjusting screw (18) from adjusting bush (15).
 9. With slotted end of spring adjusting screw (18) facing up, turn spring holder (11) clockwise and remove.
 10. Remove "O" rings (14) & (16) from spring adjusting screw (18) and adjusting bush (15) respectively.
 11. Unscrew bottom plug (1) and remove body (2).
 12. Remove "O" ring (24) from bottom plug (1).
 13. Restrain valve disc holder (3) with suitable box spanner and unscrew valve spindle (26).
 14. Withdraw valve disc holder (3), complete with valve disc (4) and valve spacer (5) through bottom plug opening.
 15. Remove valve spindle (26).
 16. Remove top diaphragm plate (20).
 17. Carefully remove main diaphragm (7).
 18. Remove diaphragm spacer (6).
 19. Remove secondary diaphragm screws (21).
 20. Carefully remove secondary diaphragm (22).
 21. Check that the hole in the impulse tube (23) is clear. (DO NOT REMOVE FROM BODY).
 22. Wipe valve seat and body clean of any dirt particles, taking care not to damage the sealing surfaces in the body.
 23. Inspect all diaphragms and soft seals, and replace where necessary (a soft spares kit is available for this purpose).

Rebuilding procedure:

1. Replace secondary diaphragm (22) with convolution uppermost into body (2), and ensure screw holes and impulse tube hole are aligned correctly.
2. Secure secondary diaphragm (22) to body (2) using screws (21).
3. Replace diaphragm spacer (6), ensuring diaphragm bead is located in groove of diaphragm spacer.
4. Replace main diaphragm (7) with convolution uppermost, ensuring that the main diaphragm bead is located in groove in body (2).
5. Replace top diaphragm plate (20), ensuring raised edge is uppermost.
6. Push valve spindle (26) through centre hole in top of diaphragm plate (20), main diaphragm (7) and diaphragm spacer (6).
7. Locate valve spacer (5) on to valve spindle (26) through bottom plug opening, with large recess facing bottom plug opening.
8. Assemble valve disc (4) on to valve disc holder (3) with bead uppermost.
9. Screw valve disc holder assembly (3) & (4) onto valve spindle (26) through bottom plug opening. (DO NOT TIGHTEN).
10. Restrain valve disc holder (3) with suitable box spanner and screw valve spindle (26) clockwise to tighten.
11. Add "O" ring (24) to bottom plug (1) recess.
12. Replace bottom plug (1) over centre shaft in valve disc holder (3), then screw tightly in position.

NOTE: If adjusting bush assembly (15) has been dismantled follow procedure, if it has been left assembled then proceed to instruction number 20.

13. Slide "O" ring (16) over slotted end of spring adjusting screw (18) into second groove. (i.e. groove nearest thread).
14. Carefully screw top spring holder (11) anti-clockwise on to spring adjusting screw (18), with raised lettering facing away from "O" ring end when assembled (refer to drawing for correct arrangement).
15. Slide "O" ring (14) into "O" ring groove on adjusting bush (15).
16. Push spring adjusting screw (18) into hole in bottom of adjusting bush (15) until both parts are firmly together.
17. Position key hole slot in locking lever (13) over slotted end of spring adjusting screw (18) and slide over sloping peg in adjusting bush (15), until firmly locked in position.
18. Screw top spring holder (11) anti-clockwise to within 10mm of bottom of adjusting bush (15).
19. Align tension spring (25) with top spring holder (11) and rotate open coil end of tension spring (25) anti-clockwise through slot in top spring holder (11) for one revolution.
20. Position adjusting bush (15) assembly over chimney of top cover (10), and align slot in top spring holder (11) with splines in top cover (10) lower the adjusting bush (15) assembly into top cover (10).
21. While applying a slight downward force, turn the adjusting bush (15) assembly clockwise until locking lever (13) snaps into any of the three locking castellations in the top cover (10).
22. Whilst holding the top cover (10) assembly above body (2), with vent facing the outlet (unless alternative position is required), hook bottom end of tension spring (25) through hole in valve spindle (26).
23. Carefully lower the top cover (10) assembly on to the body (2), and secure using top cover screws (8).
24. Set zero regulator / proportionator to required pressure.
25. Replace top cap (12) by aligning slot in cap with sealing wire lug and push over until it clicks into position, and seal if necessary.

PARTS LIST

For J48 MkII Regulator, Zero regulator, Proportionator, Angled Regulator and Meter Union Regulator.

Sizes ½" – 2" only

ITEM	DESCRIPTION	½"	No. Off	¾"	No. Off	1"	No. Off
1	BOTTOM PLUG	J4806-017Z03	1	J4806-017Z03	1	J4806-017Z03	1
2	BODY	J4804-001+	1	J4805-005+	1	J4806-094+	1
3	VALVE DISC HOLDER	J4806-015	1	J4806-015	1	J4806-015	1
4	VALVE DISC	J4806-025	* 1	J4806-025	* 1	J4806-025	* 1
5	VALVE SPACER	J4806-014	1	J4806-014	1	J4806-014	1
6	DIAPHRAGM SPACER	J4806-018	1	J4806-018	1	J4806-018	1
7	MAIN DIAPHRAGM	J4806-011	* 1	J4806-011	* 1	J4806-011	* 1
8	SCREW	JSA520XPTZ	6	JSA520XPTZ	6	JSA520XPTZ	6
9	NAMEPLATE	J8112-124	1	J8112-124	1	J8112-124	1
10	TOP COVER	J4806-103+	1	J4806-103+	1	J4806-103+	1
11	TOP SPRING HOLDER (Course thread)	J4806-098	1	J4806-098	1	J4806-098	1
12	TOP CAP	J4806-099	1	J4806-099	1	J4806-099	1
13	LOCKING LEVER	J4806-105	1	J4806-105	1	J4806-105	1
14	"O" RING SEAL	JO200032-4475	* 1	JO200032-4475	* 1	JO200032-4475	* 1
15	ADJUSTMENT BUSH (Old Design)	J4806-100	1	J4806-100	1	J4806-100	1
16	"O" RING SEAL	JORM0051-16	* 1	JORM0051-16	* 1	JORM0051-16	* 1
17	LOADING SPRING	SEE TABLE	1	SEE TABLE	1	SEE TABLE	1
18	SPRING ADJUSTING SCREW (Course thread)	J4806-097	1	J4806-097	1	J4806-097	1
19	VALVE SPINDLE	JSA440IPNZ	1	JSA440IPNZ	1	JSA440IPNZ	1
20	TOP DIAPHRAGM PLATE	J4806-003	1	J4806-003	1	J4806-003	1
21	SCREW	JSA410XPTZ	6	JSA410XPTZ	6	JSA410XPTZ	6
22	SECONDARY DIAPHRAGM	J4806-095	* 1	J4806-095	* 1	J4806-095	* 1
	AIR SECONDARY DIAPHRAGM	J4806-084	* 1	J4806-084	* 1	J4806-084	* 1
23	IMPULSE TUBE	J4706-072		J4706-072		J4706-072	
24	"O" RING SEAL	JORM0376-24	* 1	JORM0376-24	* 1	JORM0376-24	* 1
25	TENSION SPRING (To Sept '97)	J4806-106	1	J4806-106	1	J4806-106	1
26	VALVE SPINDLE (FOR ZERO) (To Sept '97)	J4806-109	1	J4806-109	1	J4806-109	1
27	COUNTER SINK PLUG	JMFC14906	1	JMFC14906	1	JMFC14906	1
28	OUTLET ADAPTOR BUSH	J4806-024+	1	J4806-024+	1	J4806-024+	1
29	METER UNION ASEMBLY	-----	-	-----	-	-----	-
30	INLET ADAPTOR BUSH	-----	-	-----	-	-----	-
31	LOADING SPRING (After Oct '97)	J4806-125	1	J4806-125	1	J4806-125	1
32	ORIENTATION LABEL	J7806-027	1	J7806-027	1	J7806-027	1
33	TOP SPRING HOLDER (Fine Thread)	J4806-127	1	J4806-127	1	J4806-127	1
34	WASHER	J4806-134	* 1	J4806-134	* 1	J4806-134	* 1
35	ADJUSTMENT BUSH (New Design)	J4806-100Z01	1	J4806-100Z01	1	J4806-100Z01	1
36	SPRING ADJUSTING SCREW (Fine Thread)	J4806-128	1	J4806-128	1	J4806-128	1
37	CIRCLIP	JCIR1500-080Z	1	JCIR1500-080Z	1	JCIR1500-080Z	1

ITEM	DESCRIPTION	1¼"	No. Off	1½"	No. Off	2"	No. Off
1	BOTTOM PLUG	J4808-017Z03	1	J4808-017Z03	1	J4809-017Z03	1
2	BODY	J4807-011+	1	J4808-084+	1	J4809-071+	1
3	VALVE DISC HOLDER	J4808-015	1	J4808-015	1	J4809-015	1
4	VALVE DISC	J4808-035	* 1	J4808-035	* 1	J4809-027	* 1
5	VALVE SPACER	J4808-014	1	J4808-014	1	J4809-014	1
6	DIAPHRAGM SPACER	J4808-021	1	J4808-021	1	J4809-018	1

ITEM	DESCRIPTION	1¼"	No. Off	1½"	No. Off	2"	No. Off
7	MAIN DIAPHRAGM	J4808-011	* 1	J4808-011	* 1	J4809-011	* 1
8	SCREW	JSA520XPTZ	8	JSA520XPTZ	8	JSA520XPTZ	8
9	NAMEPLATE	J8112-124	1	J8112-124	1	J8112-124	1
10	TOP COVER	J4808-078+	1	J4808-078+	1	J4809-067+	1
11	TOP SPRING HOLDER (Course thread)	J4806-098	1	J4806-098	1	J4806-098	1
12	TOP CAP	J4806-099	1	J4806-099	1	J4806-099	1
13	LOCKING LEVER	J4806-105	1	J4806-105	1	J4806-105	1
14	"O" RING SEAL	JO200032-4475	* 1	JO200032-4475	* 1	JO200032-4475	* 1
15	ADJUSTMENT BUSH (Old Design)	J4806-100	1	J4806-100	1	J4806-100	1
16	"O" RING SEAL	JORM0051-16	* 1	JORM0051-16	* 1	JORM0051-16	* 1
17	LOADING SPRING	SEE TABLE	1	SEE TABLE	1	SEE TABLE	1
18	SPRING ADJUSTING SCREW (Course thread)	J4806-097	1	J4806-097	1	J4806-097	1
19	VALVE SPINDLE	JBA650HEXZG	1	JBA650HEXZG	1	JBA865HEXZG	1
20	TOP DIAPHRAGM PLATE	J4808-003	1	J4808-003	1	J4809-003	1
21	SCREW	JSA510XPTZ	6	JSA510XPTZ	6	JSA510XPTZ	8
22	SECONDARY DIAPHRAGM	J4808-070	* 1	J4808-070	* 1	J4809-070	* 1
	AIR SECONDARY DIAPHRAGM	J4808-074	* 1	J4808-074	* 1	J4809-064	* 1
23	IMPULSE TUBE	J4808-076	1	J4808-076	1	J4709-060	1
24	"O" RING SEAL	JORM0546-24	* 1	JORM0546-24	* 1	JORM0745-30	* 1
25	TENSION SPRING	-----	-	-----	-	-----	-
26	VALVE SPINDLE (FOR ZERO)	-----	-	-----	-	-----	-
27	COUNTER SINK PLUG	JMFC14907	1	JMFC14907	1	JMFC14909	1
28	OUTLET ADAPTOR BUSH	J4807-003+	1	J4807-003+	1	J4809-022+	1
29	METER UNION ASEMBLY	JMU020LJ48	-	JMU050LJ48	-	JMU100LJ48	-
30	INLET ADAPTOR BUSH	J4707-003	1	J4707-003	1	J4709-044	1
31	LOADING SPRING	J4806-020	1	J4806-020	1	J4806-020	1
32	ORIENTATION LABEL	J7806-027	1	J7806-027	1	J7806-027	1
33	TOP SPRING HOLDER (Fine Thread)	J4806-127	1	J4806-127	1	J4806-127	1
34	WASHER	J4806-134	* 1	J4806-134	* 1	J4806-134	* 1
35	ADJUSTMENT BUSH (New Design)	J4806100Z01	1	J4806100Z01	1	J4806-100Z01	1
36	SPRING ADJUSTING SCREW (Fine Thread)	J4806-128	1	J4806-128	1	J4806-128	1
37	CIRCLIP	JCIR1500-080Z	1	JCIR1500-080Z	1	JCIR1500-080Z	1

Note: Part numbers marked * require connection thread to be specified with order.

SPARES KITS

Spares kit contents are marked * on parts list above

SPARES KIT CODE	SIZE
SK4806-01	½" – 1"
SK4808-01	1¼" – 1½"
SK4809-01	2"

SPRINGS FOR J48 (½", ¾", 1", 1¼", 1½" & 2")

(J48 Regulator, Angled Regulator and Meter union Regulator)

SPRING RANGE		PART NUMBER AND COLOUR CODE		
"wg	mbar	½", ¾" & 1"	1¼" – 1½"	2"
2 – 6	5 – 15	J4806-007 YELLOW	J4808-004 RED / YELLOW	J4809-007 DARK BLUE / YELLOW
5 – 10	12.5 – 25	J4806-004 BLACK	J4808-007 RED / BLACK	J4809-004 DARK BLUE / BLACK
9 – 14	22.5 – 35	J4806-005 ORANGE	J4808-008 RED / ORANGE	J4809-005 DARK BLUE / ORANGE
10 – 30	25 – 75	J4806-101 YELLOW / BLACK	J4808-077 YELLOW / ORANGE	J4809-066 YELLOW / DARK GREEN
28 – 40	70 – 100	J4806-079 PINK / GOLD	J4808-075 PINK / SILVER	J4809-065 GREY / GOLD
36 – 64	90 – 160	J4808-077 YELLOW / ORANGE	J4809-065 GREY / GOLD	-----

Note: For Zero Regulator and Proportionator see parts list for spring part number.

COMMISSIONING

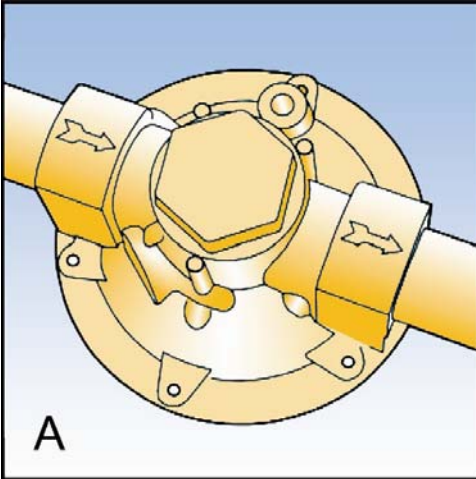

OPERATING INSTRUCTIONS

- Ensure that this product is suitable for the chosen application.
- Installation, adjustment and maintenance by authorised, trained personnel only.
- When being fitted to an appliance, refer to the appliance manufacturers instructions.
- The unit should not be installed in a corrosive environment.
- The ambient temperature (surface temperature) should be within the limits stated on the regulator catalogue.

Warning! Incorrect installation, adjustment, modification, operation and maintenance may cause injury or damage.
Read the instructions before use. This control must be installed in accordance with the rules in force.

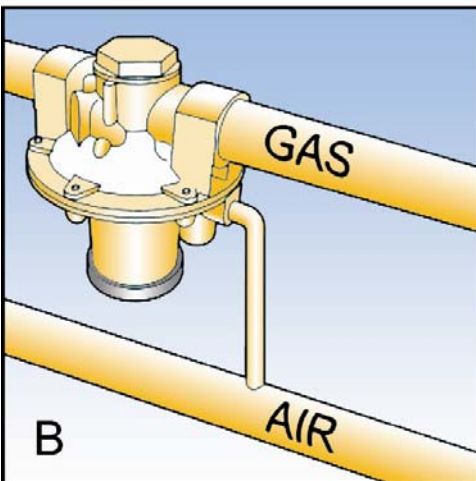

FITTING UNIT INTO PIPEWORK (A)

1. Remove the plastic protection plugs from inlet, outlet and impulse.
2. Ensure that installation pipework is thoroughly clean.
3. The direction of gas flow must be the same as the arrow(s) on the unit body.
4. Install the unit into horizontal pipework with the spring housing pointing vertically downwards. Use a jointing compound approved to national standards.

INSTALLATION OF AIR CONTROL LINE (B) IF REQUIRED

5. Remove the plastic protection plug.
6. Connect the air control line (Rc1/4 connection), using a jointing compound approved to national standards. Connection of air line will depend upon the specification of the overall installation.

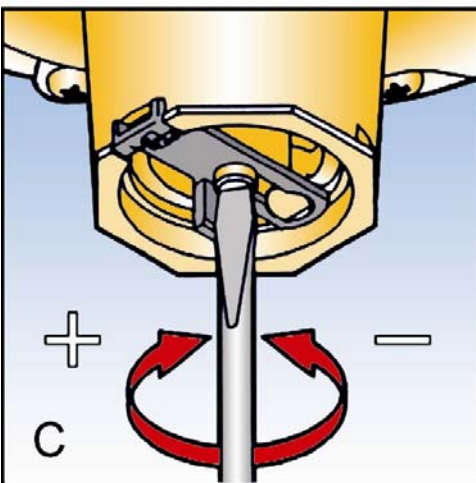

ADJUSTMENT OF OUTLET PRESSURE (C).

7. Small changes to the outlet pressure can be made by removing the cap at the base of the spring housing and turning the spring adjusting screw clockwise to increase pressure or anticlockwise to reduce the outlet pressure.
8. Replace the cap (and seal if necessary). If necessary).