

# A3 ALPHA<sup>®</sup> meter



In support of open architecture standards, the A3 ALPHA meter fully supports ANSI C12.18, C12.19, and C12.21.

## Interval data recording and self reads

The main circuit board has nonvolatile memory for storing profile, data logs, and self read data. Recording options include interval profiles of instrumentation data and up to 15 self reads. If extensive profile recording is required, an extended memory option board can be easily added to increase total memory by 1 MB.

When optional instrumentation profiling is enabled, the meter stores 2 separate sets of instrumentation data. Each data set has an independent interval length and up to 16 channels. With instrumentation profiling, each meter becomes a powerful data collection tool to monitor data and diagnose problems without installing expensive temporary monitoring equipment. One of over 50 instrumentation quantities can be assigned to each channel, and the storage algorithm for each channel can be independently selected. Four storage algorithms are available:

- minimum value per interval
- maximum value per interval
- average value per interval
- end of interval snapshot

## Revenue metering

The A3 ALPHA meter is a very accurate revenue meter (0.2 accuracy Class). Existing ALPHA meter users will find the basic A3 ALPHA meter types familiar. The meter provides advanced four quadrant revenue functions, transformer and line loss compensation, and increased data profiling without adding hardware option boards.

Meter type	Measured quantities
A3D	1 (watthours only)
A3T	1 (watthours only)
A3K, A3R, A3Q	2 (user selectable)
A3KA, A3RA	6 (user selectable)
A3QA	

Each measured quantity is stored in nonvolatile memory and includes energy, demand, and TOU data. Note. TOU data is not available for A3D.

## Power quality monitoring

PQM provides continuous service condition monitoring 24 hours a day. PQM looks for exceptions to user-defined thresholds for items such as voltage, current, and total harmonic distortion. Each of the 12 PQM tests can be configured to control relay activation, LCD warning, date/time stamp log entry, and even an automatic telephone call to report the condition.



Elster's A3 ALPHA meter builds on the strengths of the ALPHA meter design. The patented digital measurement techniques offer high accuracy, repeatability, and low ownership costs.

### A communication enabler

Data can be retrieved using the standard optical communications port. Additional communications interfaces are available for A3 ALPHA meters as a simple add-on option board:

- 2400 bps internal telephone modem with outage reporting capabilities
- RS-232
- RS-485
- external serial interface
- 20 mA current loop
- internal LAN controller (ILC1)
- internal LAN node (ILN1)
- Itron 50ESS ERT®
- Aclara TWACS UMT-C-A3 transponder

Communications interfaces can be combined with alarming options in the A3 ALPHA meter to permit immediate notification of critical events.

The relay option boards of all existing ALPHA meters are compatible with the A3 ALPHA meter. When relay option boards are used with the A3 ALPHA meter, the relay functions are fully programmable.

### AnyPhase™ power supply

With the optional AnyPhase power supply installed, the A3 ALPHA meter is powered from all wires of the electrical service. If one or more service wires are disconnected, the meter is automatically powered from any two service wires including line-to-line or line-to-neutral.

### About Elster Group

A world leader in advanced metering infrastructure, integrated metering, and utilization solutions to the gas, electricity and water industries, Elster's systems and solutions reflect over 170 years of knowledge and experience in measuring precious resources and energy. Elster provides solutions and advanced technologies to help utilities more easily, efficiently and reliably obtain and use advanced metering intelligence to improve customer service, enhance operational efficiency, and increase customer benefits. Elster's AMI solutions enable utilities to cost-effectively deliver, manage, and conserve the life-essential resources of gas, electricity, and water. Elster has over 7500 staff and operations in 38 countries in North and South America, Europe, and Asia.

Maximum voltage	Continuous 528 VAC (AnyPhase option: L-L or L-N)	
Maximum current	Continuous at Class amperes; temporary (1 second) at 200 % of meter maximum current	
Surge voltage withstand	ANSI C37.90.1 Oscillatory	2.5 kV, 2500 strikes
	Fast transient	5 kV, 2500 strikes
	ANSI C62.41	6 kV at 1.2/50 μs, 10 strikes
	IEC 61000-4-4	4 kV, 2.5 kHz repetitive burst for 1 minute
	ANSI C12.1 Insulation	2.5 kV, 60 Hz for 1 minute
Voltage range	Nameplate nominal range	120 V to 480 V
	Operating range	96 V to 528 V
Current range	0 to Class amperes	
Frequency range	Nominal 50 Hz or 60 Hz ± 5 %	
Temperature range	-40 °C to +85 °C inside the meter cover	
Humidity range	0 % to 100 % noncondensing	
Power supply burden	Less than 4 W	
Per phase current burden	0.1 milliohms typical at 25 °C	
Per phase voltage burden	0.008 W at 120 V; 0.03 W at 240 V; 0.04 W at 480 V	
Accuracy	Meets ANSI C12.20 accuracy for accuracy Class 0.2 %	
Starting current	Forms 1S and 3S	10 mA for Class 20
		100 mA for Class 200
		160 mA for Class 320
	All other forms	5 mA for Class 20 50 mA for Class 200 80 mA for Class 320
Primary time base	Power line frequency (50 Hz or 60 Hz) with selectable crystal oscillator	
Secondary time base	Meets the ANSI limit of 0.02 % using the 32.768 kHz crystal. Initial performance is expected to be equal to or better than ±5 seconds per month at room temperature.	
Outage carryover capacity	6 hours at 25 °C. Super capacitor rated at 0.1 Farads, 5.5 V.	
Communication rates	Optical port: 300 to 28,800 bps; Remote port: 1200 to 19,200 bps	
ANSI standards	C12.1; C12.10; C12.18; C12.19; C12.20; C12.21	

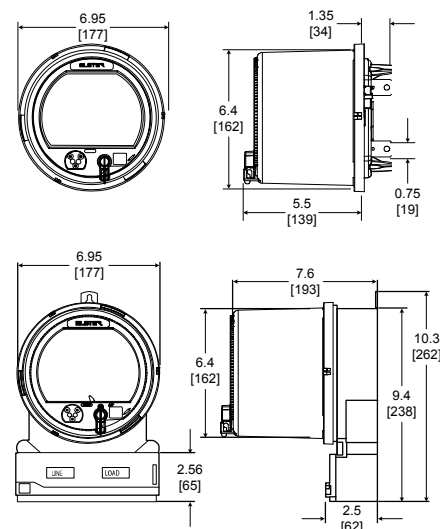

Dimensions in inches [millimeters]. For reference only.

Elster  
208 S Rogers Lane  
Raleigh, NC 27610-2144  
United States

T +1 800 338 5251 (US toll free)  
T +1 905 634 4895 (Canada)  
F +1 919 212 4801

www.elster.com

© 2008 by Elster. All rights reserved.

Information contained herein is subject to change without notice. Product specifications may change. Contact your Elster representative for the most current product information. Printed in the United States.